

**Note:**

These exploded views apply only to version 2.0.  
The version can be determined from the 9th digit of the  
8 number on the nameplate **A** (8.xxx.xxx.x**2**xxx).

ID	Service parts	S-RS	Description
A-01	6.000.205.582	S	Flow boiler B 10(HW)
A-02	6.016.008.052	RS	High temperature safety switch
A-03	6.000.211.757	S	Lid for hot water tank
A-04	6.311.090.001	S	Descaling plug
A-05	6.311.087.001	S	Lid column B HW
A-06	6.311.112.001	S	Gasket
A-07	6.236.158.000	RS	Heating element 240V 1200W
A-08a	6.205.855.000	S	Electrodes + support B and B HW standard
A-08b	6.305.052.000	S	Electrodes + support B and B HW special
A-09a	6.205.856.000	S	Electrodes + support B HW standard
A-09b	6.305.053.000	S	Electrodes + support B HW special
A-10	6.205.851.001	DT	Water tank column B HW-series
A-11	6.016.008.064	RS	High temp. safety switch 115°C
A-12	6.001.045.002	S	Nut 3/8 chrome-plated brass
A-13	6.011.001.201	S	O-ring 19x2
A-14	6.236.243.001	S	Nipple for tank
A-15	6.011.001.055	RS	O-ring 24x4
A-16	6.236.188.000	RS	Temperature sensor (assy)
A-17	6.011.031.001	S	Gasket
A-18	6.205.857.000	S	Hot water reservoir B10 HW-2

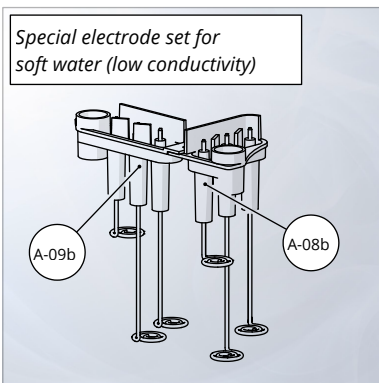
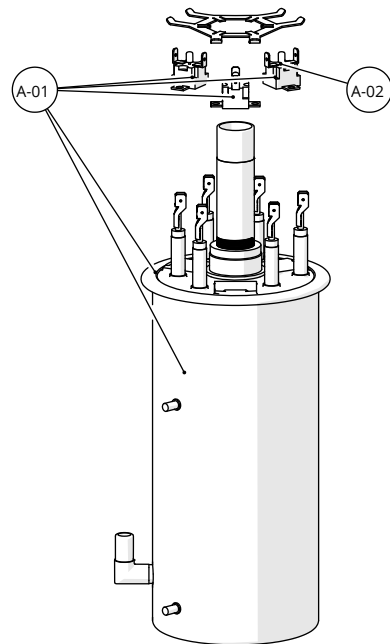
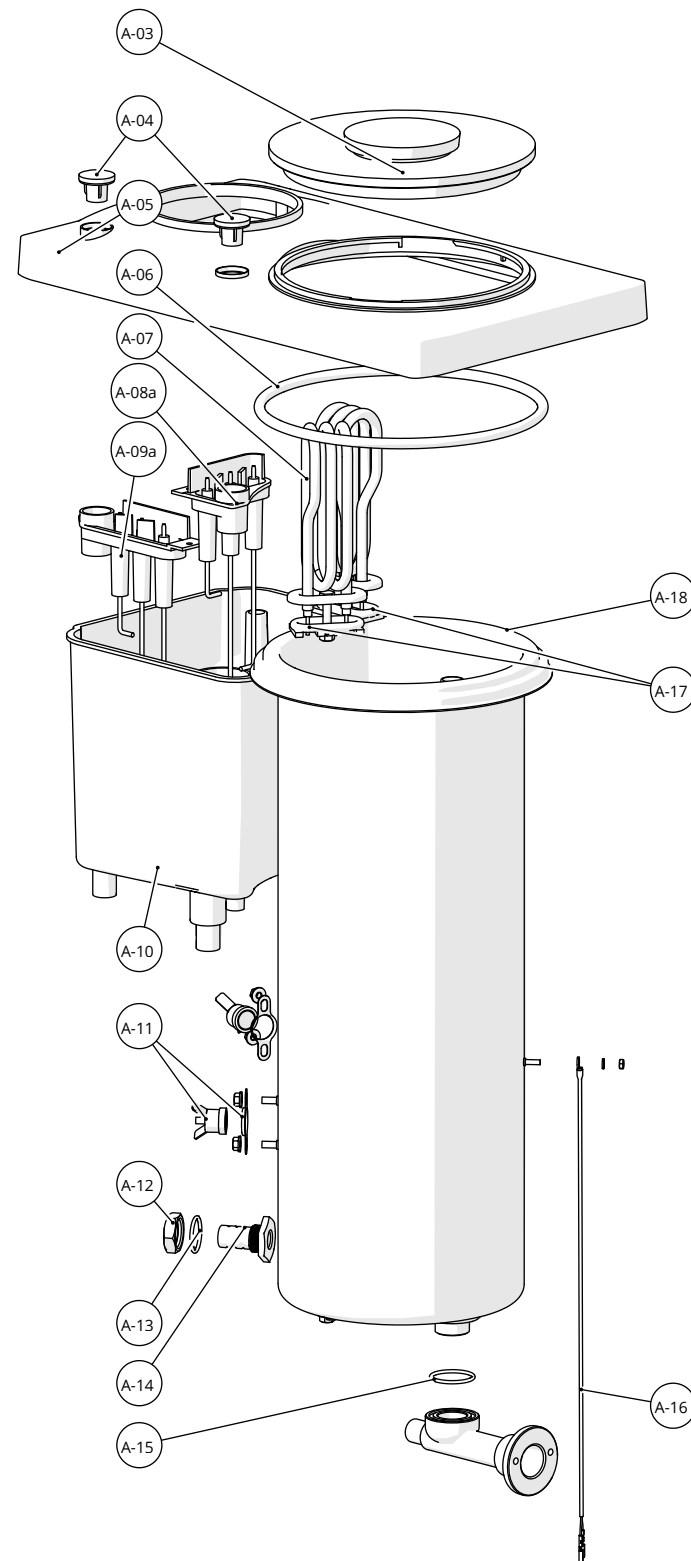

ID	Service parts	S-RS	Description	mm
B-01	6.000.205.111	S	Connection tube 1.5 m	
B-02	6.016.001.026	RS	Magnetic valve 2.5 l/0.5 l	
B-03	6.001.079.003	S	Tube clamp 15.6 mm	
B-04	6.001.079.006	S	Tube clamp 19 mm	
B-05	6.019.033.014	S	Silicone tube 9.5x3	610
B-06	6.019.033.014	S	Silicone tube 9.5x3	320
B-07	6.016.024.004	RS	Flow meter	
B-08	6.019.033.014	S	Silicone tube 9.5x3	570
B-09	6.205.853.001	S	Cover waterinlet	
B-10	6.311.113.001	S	Tube 9.5/12.5x2.5	215
B-11	6.019.033.014	S	Silicone tube 9.5x3	90
B-12	6.019.033.012	S	Silicone tube 20x2.5	70
B-13	6.205.826.000	S	Ascending pipe	
B-14	6.205.854.001	S	Sleeve ascending pipe B 5 / B 10	
B-15	6.011.001.060	RS	O-ring 23x4	
B-16	6.017.003.006	S	Magnet swivel arm	
B-17	6.311.098.001	S	Knob swivel arm	
B-18a	6.311.120.000	S	Swivel arm B 5HW / B 10HW	
B-18b	6.311.119.000	S	Swivel arm WDB 5 / WDB 10HW	
B-19	6.019.033.014	S	Silicone tube 9.5x3	240
B-20	6.006.002.018	S	Tightening plug 10.1x18x18	
B-21	6.019.033.013	S	Silicone tube 11.5x3	230
B-22	6.019.033.013	S	Silicone tube 11.5x3	70
B-23	6.019.033.013	S	Silicone tube 11.5x3	30
B-24	6.011.001.057	RS	O-ring 14x3.5	
B-25	6.214.066.001	S	Tap housing without gauge glass	
B-26	6.214.060.001	S	Cover for tap	
B-27	6.015.001.213	RS	Rubber cup	
B-28	6.015.001.214	S	Lever rod tap	
B-29	6.015.001.215	RS	Compression spring for tap	
B-30	6.214.058.001	S	Screwcap	
B-31	6.214.056.001	S	Tap handle	
B-32	6.015.001.365	S	Upper part for tap	
B-33	6.229.760.001	S	Nipple	

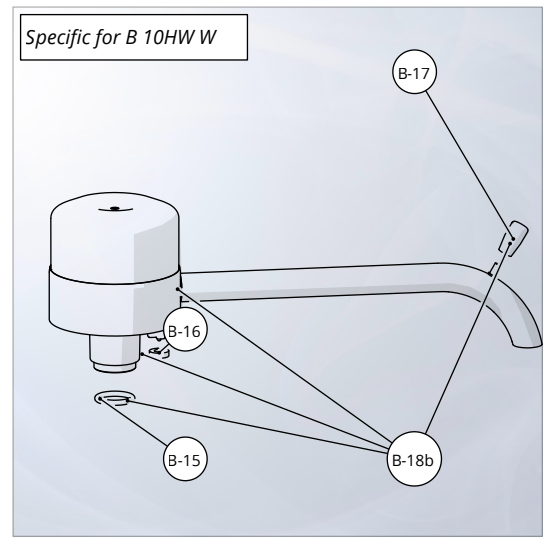
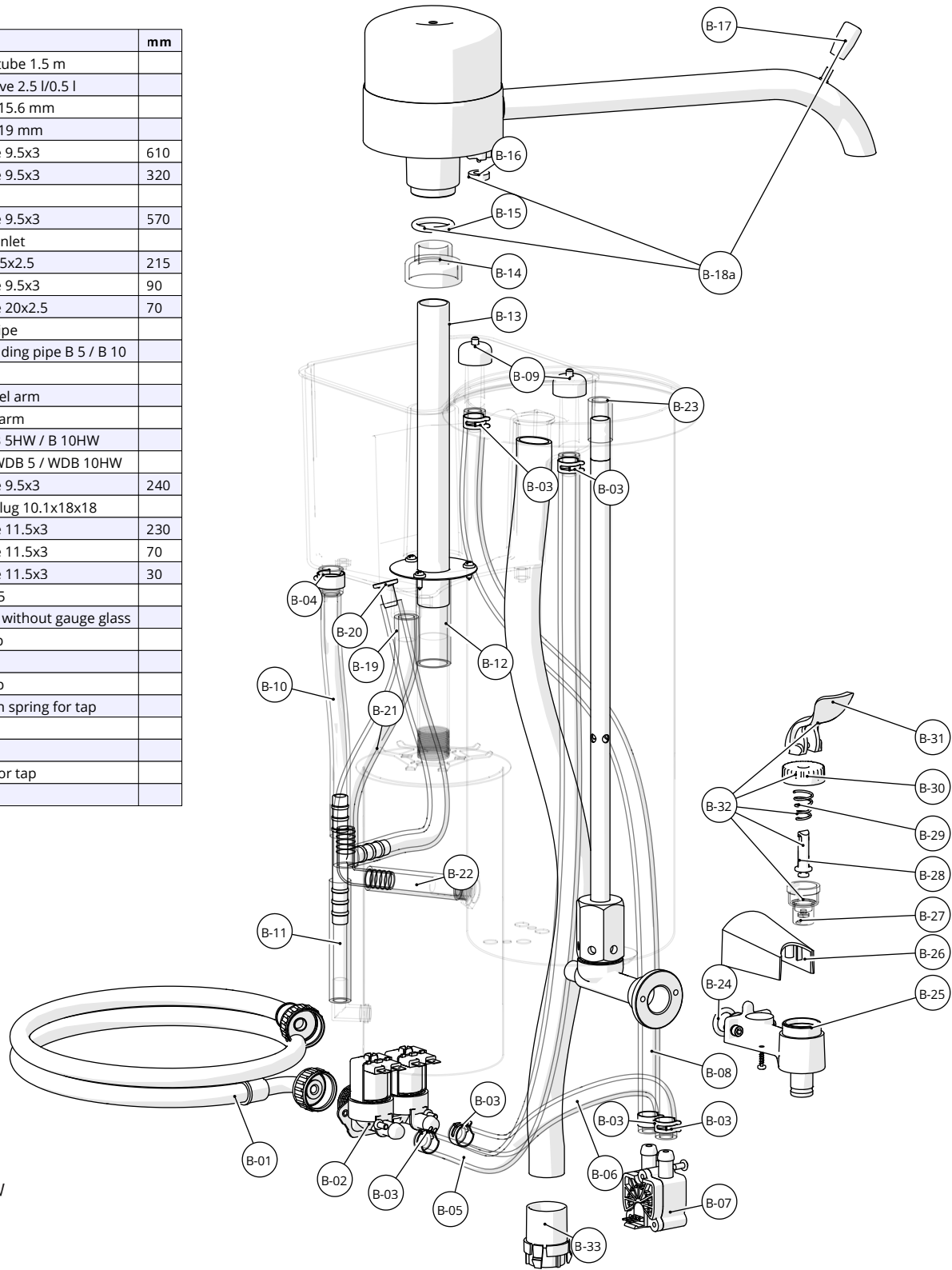

ID	Service parts	S-RS	Description
C-01	6.006.001.009	S	Cord inlet
C-02	6.211.772.000	S	RC combination
C-03	6.002.019.160	S	Wiring strip
C-04a	6.004.002.103	RS	Relay 50Hz (STD)
C-04b	6.004.002.104	RS	Relay 60Hz
C-05	6.305.043.000	RS	Flat cable
C-06	6.305.036.000	RS	Mainboard B HW-series
C-07	6.005.011.015	S	Fuse 2A (10 pcs)
C-08	6.005.012.008	S	Fuse holder </td
C-09a	6.006.005.100	S	Socket (STD)
C-09b	6.006.005.103	S	Socket (CH)
C-09c	6.006.005.104	S	Socket (GB)
C-09d	6.006.005.107	S	Socket (AUS)
C-09e	6.006.005.108	S	Socket (DK)
C-10	6.205.865.000	S	Flap for socket left
C-11	6.205.864.000	S	Flap for socket rigth
C-12	6.401.217.001	S	Adapter switch
C-13	6.004.001.069	RS	Switch
C-14	6.205.859.001	S	Service panel
C-15	6.205.862.001	S	Push buttons
C-16	6.205.860.001	S	Window service panel
C-17	6.305.034.000	RS	Keyboard
C-18	6.205.920.000	S	Reed switch B 5HW / B 10HW
C-19	6.006.010.055	S	Cable clip
C-20	6.006.010.078	S	Wire clip 10 mm

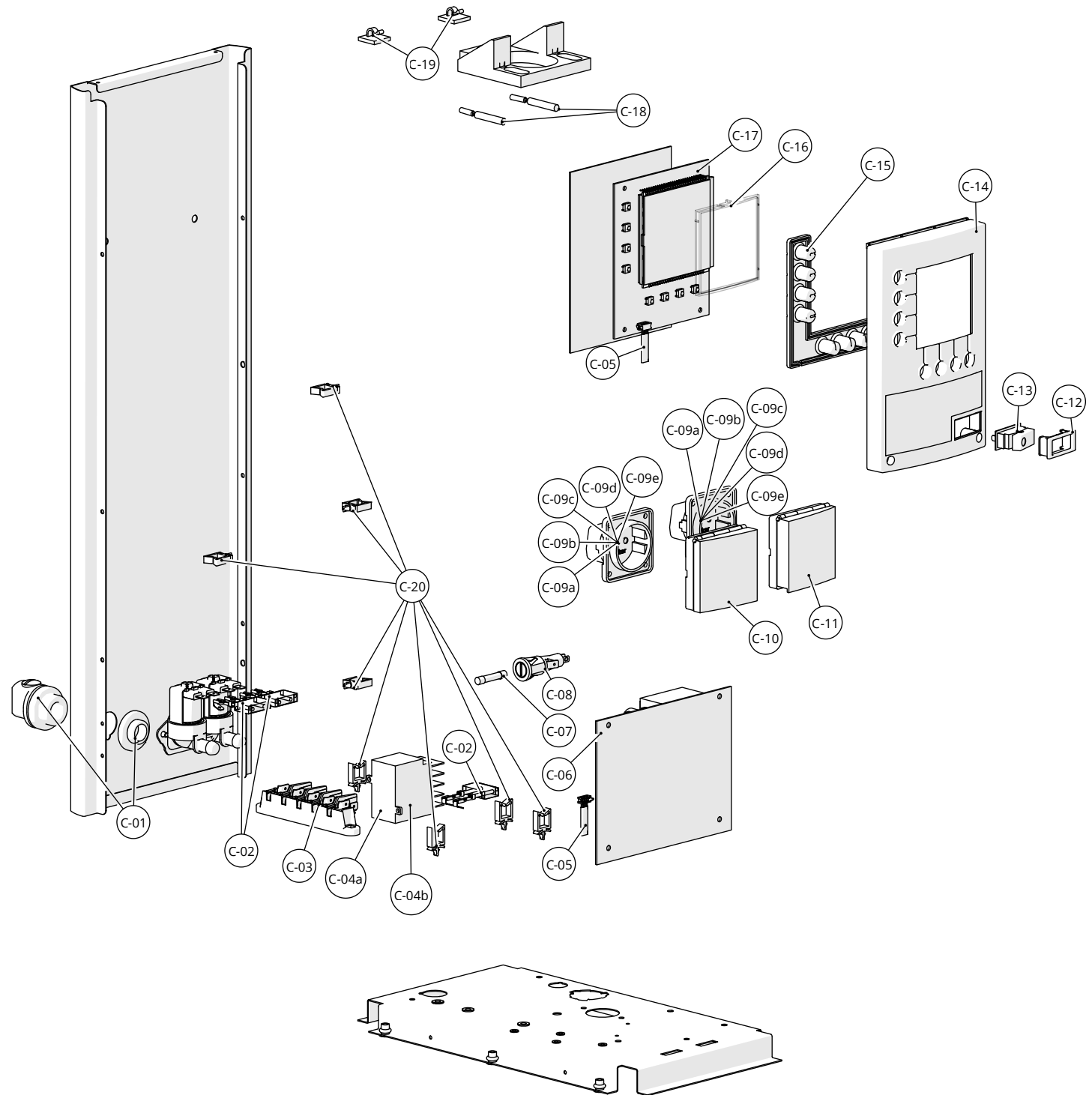

ID	Service parts	S-RS	Description
D-01	6.311.072.001	S	Foot B-series
D-02	6.006.010.084	DT	Cable clip
D-03	6.311.218.001	S	Reed switch safety
D-04	6.206.630.000	S	Reed switch
D-05	6.311.126.001	S	Cam
D-06	6.311.204.001	S	Sealing ring base B-series
D-07	6.311.203.001	S	Cap reed contact switch

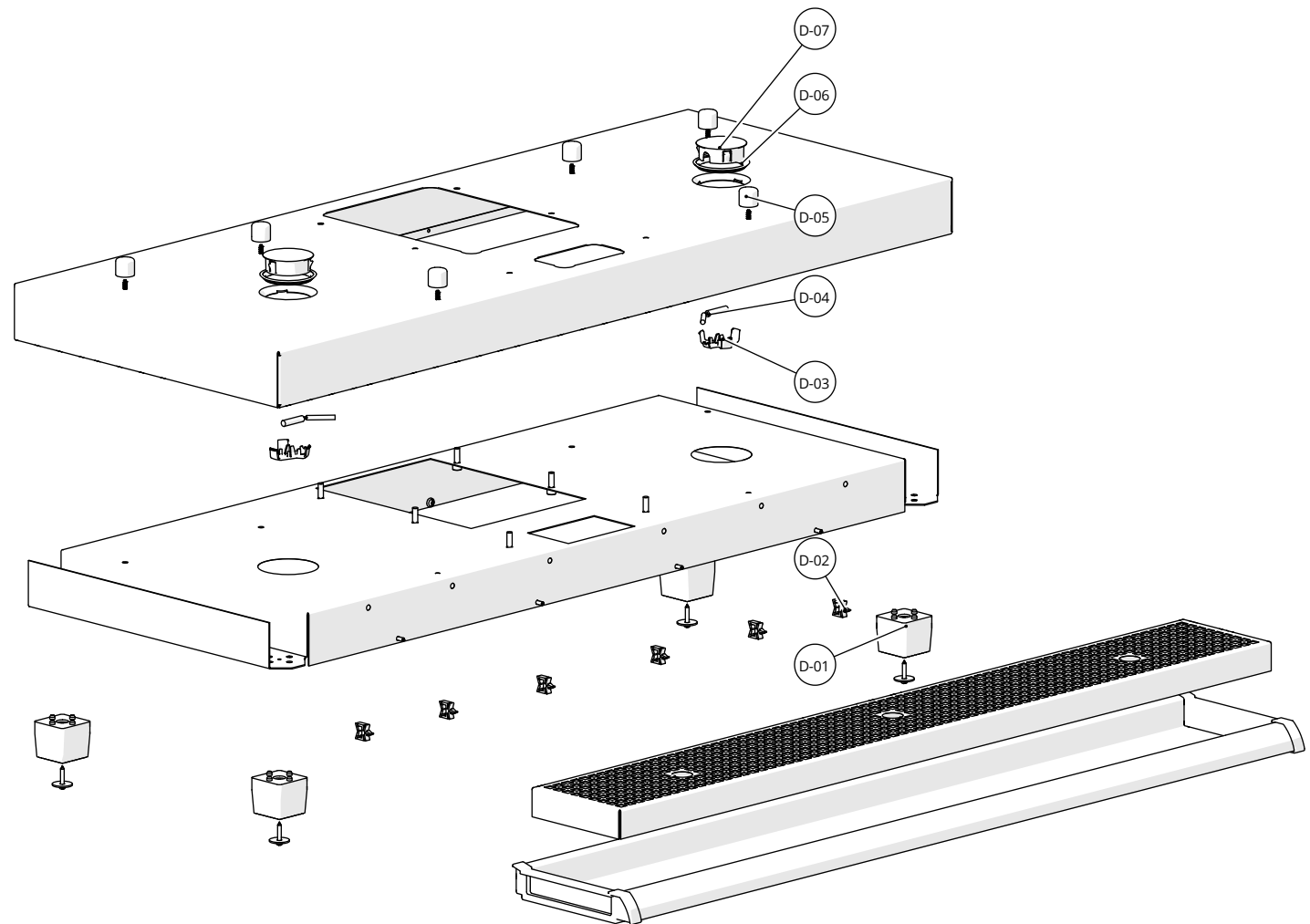

ID	Service parts	S-RS	Description
E-01	6.242.198.001	S	Handle VHG 10
E-02	6.240.145.001	S	Knob lid
E-03	6.006.001.101	S	Cord inlet with pull relief
E-04	6.311.196.001	S	Magnet support
E-05	6.017.003.006	S	Magnet
E-06	6.004.001.081	RS	Switch 230V
E-07	6.240.139.001	S	Cord support grey
E-08	6.011.001.055	RS	O-ring 24x2
E-09	6.242.206.000	RS	PTC element VHG 10
E-10	6.242.190.000	S	Inner urn
E-11	6.240.134.001	S	Cap gauge glass
E-12	6.242.192.001	S	Case for gauge glass VHG 10
E-13	6.242.203.001	S	Strip for gauge glass VHG 10
E-14	6.242.193.001	S	Gauge glass VHG 10
E-15	6.011.001.112	S	O-ring 12x3
E-16	6.015.001.366	S	Upper part for tap
E-17	6.242.191.001	S	Tap handle
E-18	6.242.183.001	S	Screw cap tap housing
E-19	6.015.001.027	RS	Spring
E-20	6.015.001.281	S	Lever rod tap
E-21	6.015.001.006	RS	Rubber cup
E-22	6.242.187.001	S	Tap cover VHG 10 / 20 / 40
E-23	6.242.181.001	S	Tap housing VHG 10 / 20 / 40
E-24	6.011.001.057	RS	O-ring 14x3.5

